

# Role of GHG Inventories in Small and Medium Industries for enhancing NAMAs in the Context of Sustainable Development

**Akio Takemoto (Ph.D.)**

**Secretariat Director**

**Asia-Pacific Network for Global Change Research (APN)**

**Senior Policy Advisor**

**Institute for Global environmental Strategies (IGES)**

**Kansai research Centre (KRC)**

# How are international communities addressing climate change ?

At 16<sup>th</sup> Conference of Framework Convention on Climate Change (2010), the Parties agreed to



- Work towards identifying a global goal for the substantially reducing global emissions by 2050
- Both developed and developing countries agreed to enhance mitigation actions
- Developing countries parties agreed to take nationally mitigation actions in the context of
  - **Sustainable development**
  - **Supported and enabled by technology**
  - **Financing and capacity-building**
  - **Develop low-carbon development strategies or plans in the context of sustainable development**

# Case of India: High increase of energy consumption, leading to increase CO<sub>2</sub> emission

## Demand

Increase of energy consumption  
(industry, agriculture, transport)

➔ Increasing CO<sub>2</sub> emission



## Supply

Lack of power supply capacity.

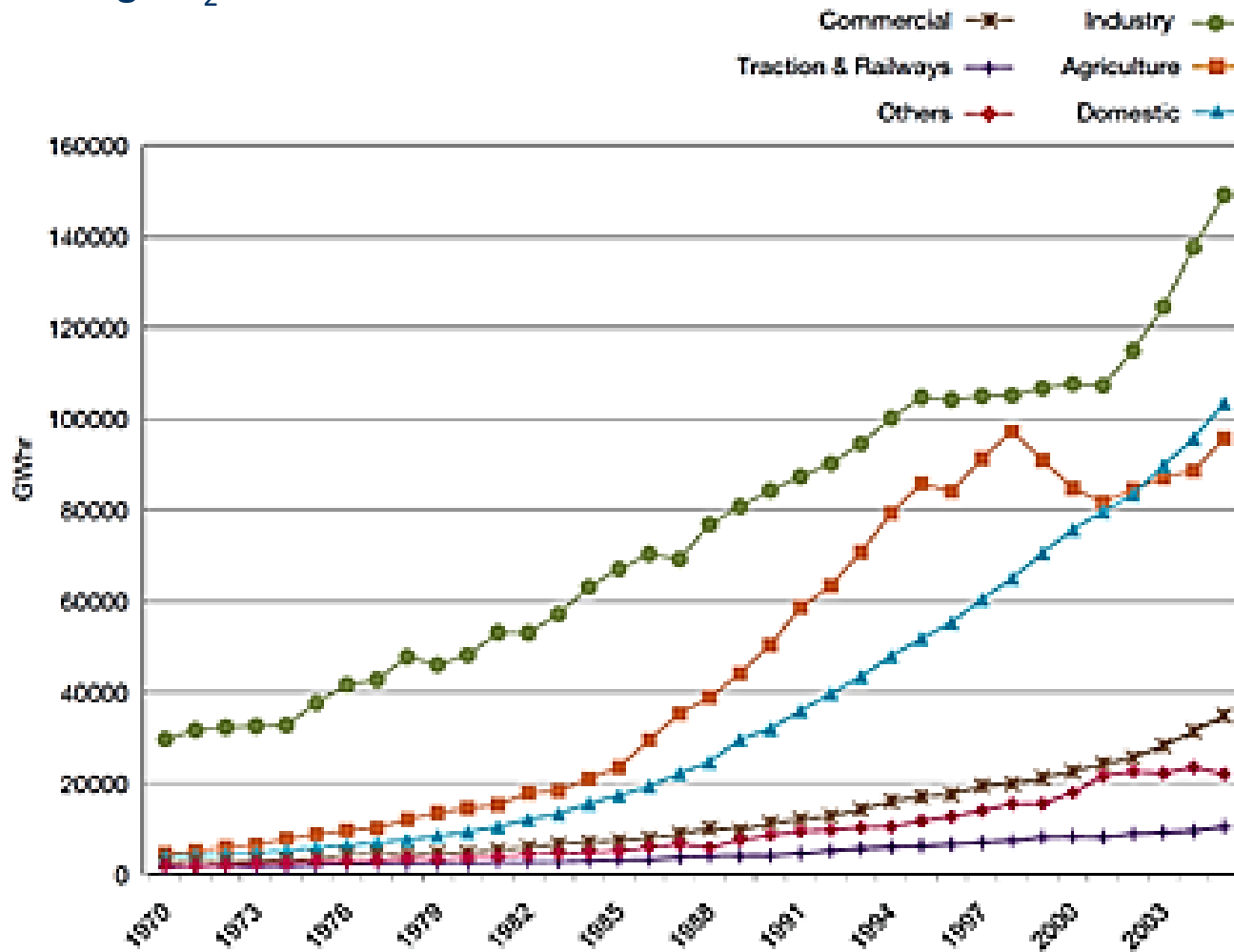

# Research Partnership for Application of Low Carbon Technology for Sustainable Development in India (ALCT)

- Support by **JICA and JST (SATREPS)**
- Implemented by **IGES and TERI** under agreement between J-I Governments
- Project term: Jun 2010 **to March 2014**

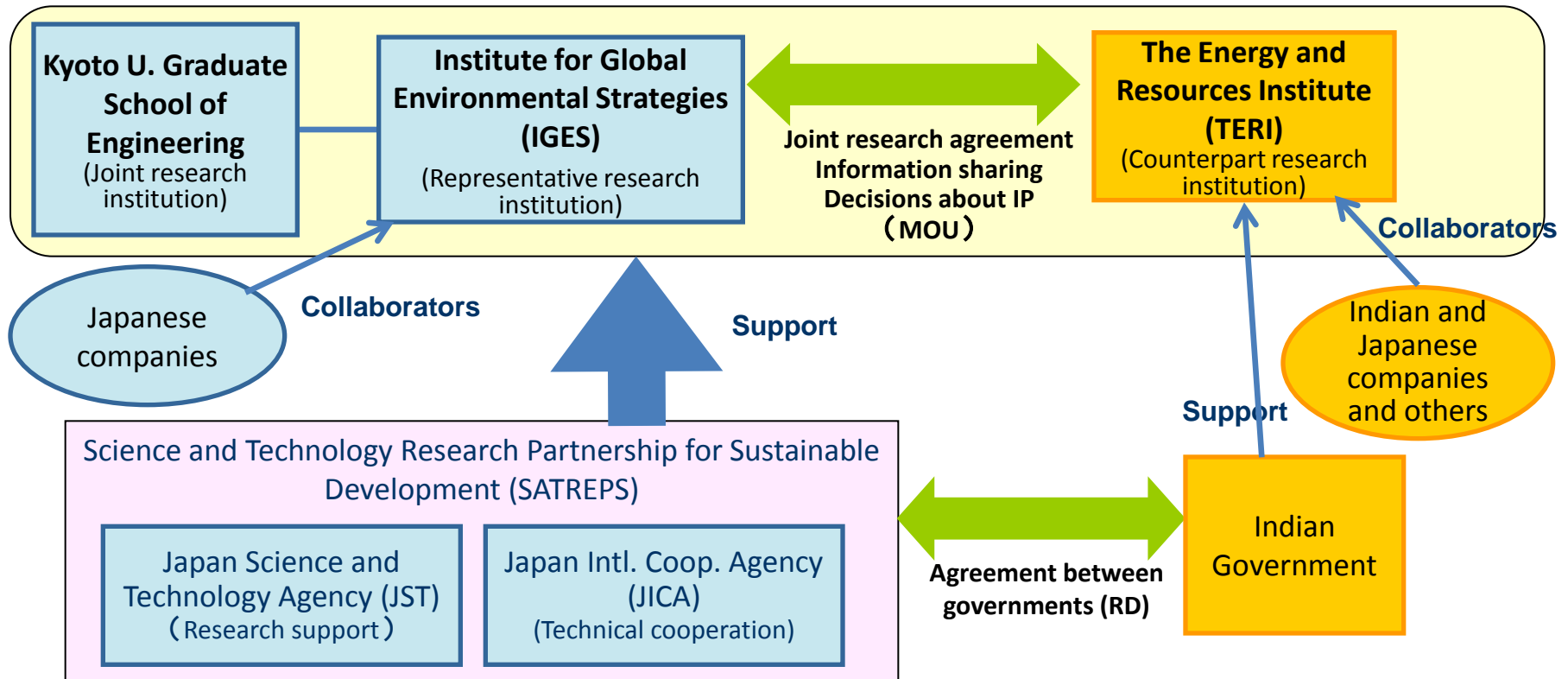

# Short list of low carbon technologies under ALCT

Target: Small & Medium Enterprises (SMEs)

Condition:(1) Low carbon emission & energy efficient

(2) Matching both for users' and suppliers' needs

## Activities:

-Investigated nearly 100 Indian industrial units in technical field missions, for potential Japanese low-carbon technologies, such as gas and electric heat pump (GHP and EHP) systems, with support from various leading Japanese companies (e.g., Panasonic, Osaka Gas, Yanmar and Mayekawa) and TERI.

-Facilitate and launch pilot experiment/demonstration for GHP and EHP systems..

- **Gas heat pump (GHP)**
- **Electric heat pump (EHP)**
- **Induction furnace**
- **Compressed air optimization**
- Micro co-generation system
- Once through boiler
- EMS (lightening management system)
- Air conditioning system (VRV)
- Ventilation system
- Amorphous transformer

# Overview of foundry industry in India

- About 5000 units in India
- 95% units belong to Small and Medium Enterprises (SMEs)
  - Medium: Annual production < 10,000 tons
  - Small: Annual production < 1,000 tons
- 4500-4700 sand-casting foundry units
- 130 lost-wax foundry units, out of which 70 in Rajkot
- Energy intensive process: melting, molding, machining, cooling, etc.
- Lack of finance
- Lack of capacity of both employees and managers
  - Working culture (top-down decision making, pay less attention to problem solving, etc.)
  - Some employees are illiterate
- Lack of information on technology (and how to use it)

# Sand casting foundry process

Molding and Sand preparation



Charging and Melting



Casting



Machining



Finishing



# Lost-wax (Investment casting) foundry process

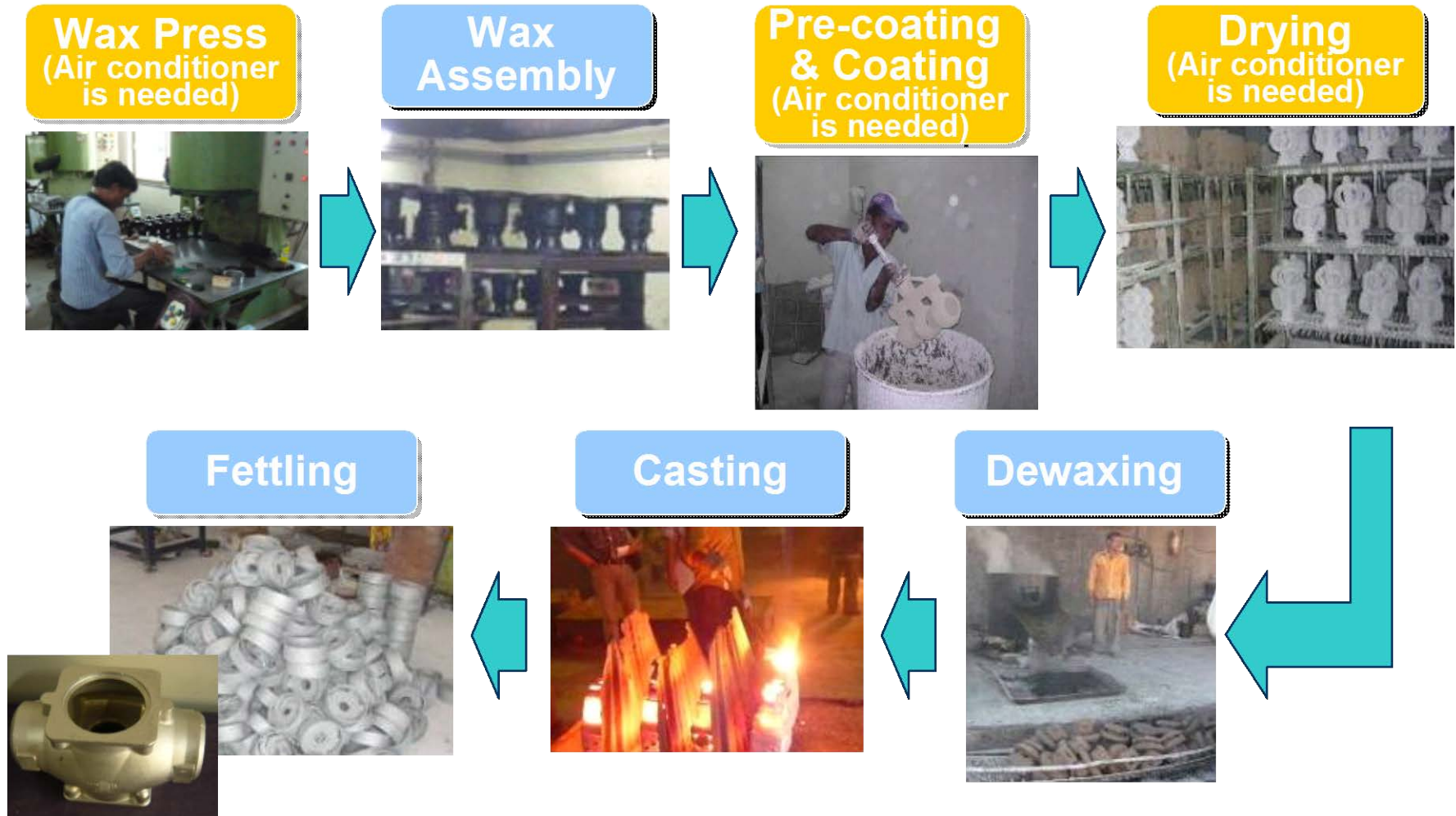



# GHP estimated impacts

## (Air-conditioning system in Induction furnace in Rajikot)

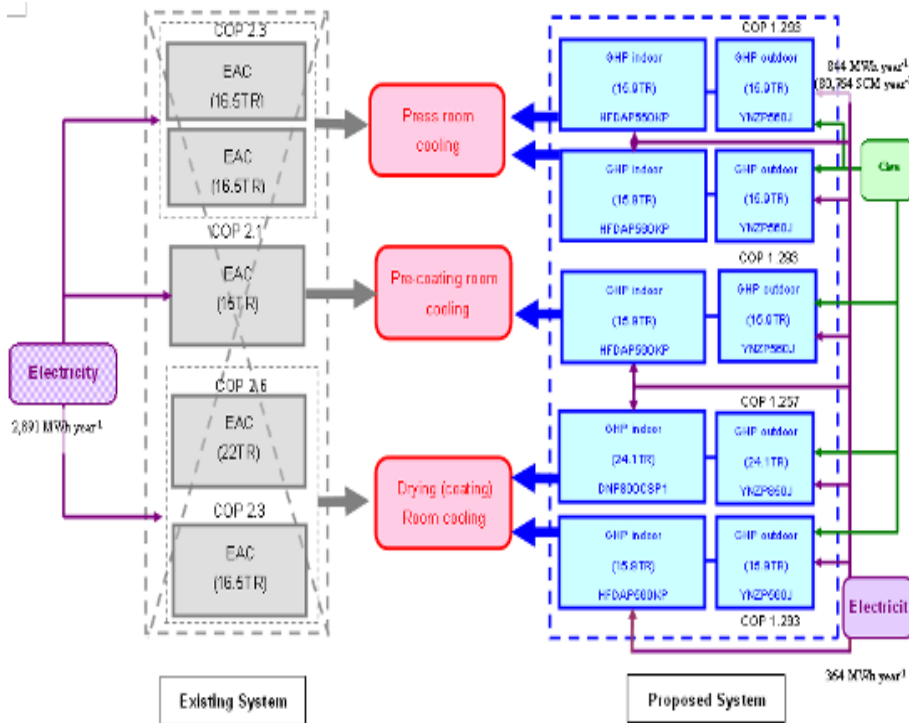

The estimated impact of applying GHP air-conditioning system to induction furnace plants in Rajikot.  
 The saving in energy cost is 35%.  
 The reduction in carbon emission is 59%.

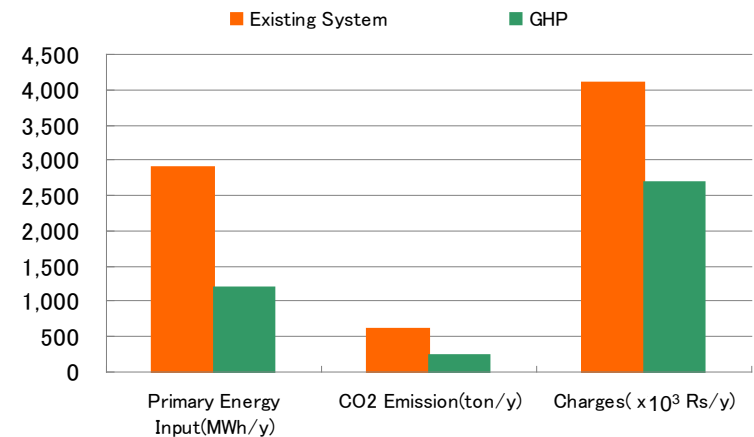

ラージコートの鋳物工場JにおけるGHP適用のイメージ

ラージコートの鋳物工場JでGHP適用した場合の推定効果

# Technology for Induction Furnace

High Frequency Induction furnaces are installed at most Foundry units in India, Hardware is equivalent level to Japanese foundries

## Secondary Melting Process

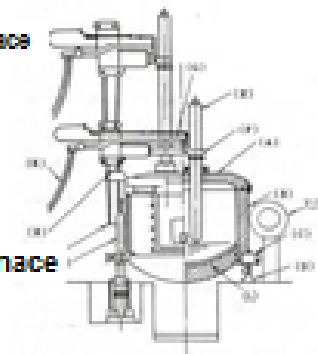
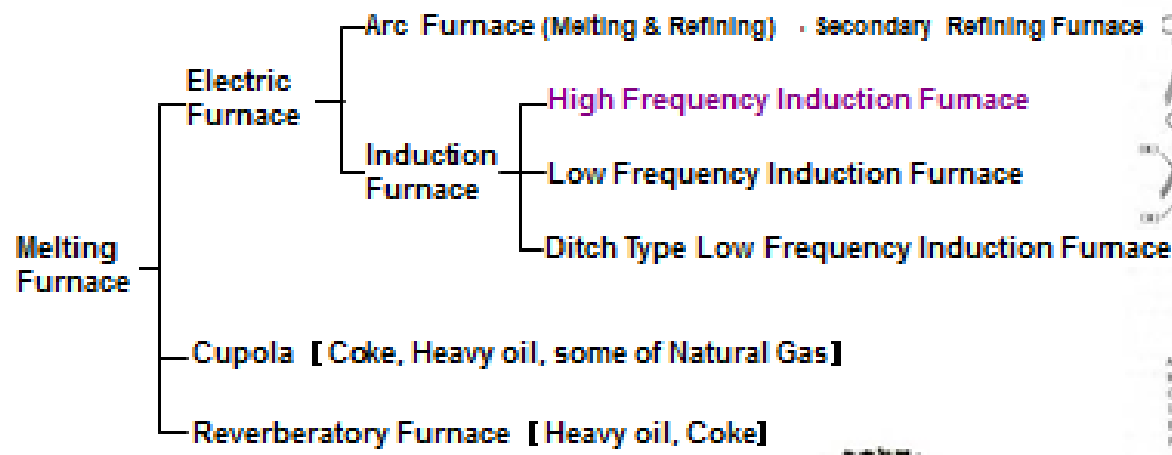

- A: 炉体
- B: 炉蓋
- C: 炉内
- D: 炉底
- E: 電機
- F: 電機用冷却機
- G: アークセンサー
- H: 電機用冷却機
- I: 電機用冷却機
- J: 電機用冷却機
- K: コールド
- L: 電機用冷却機

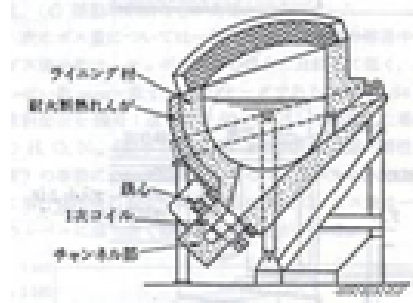
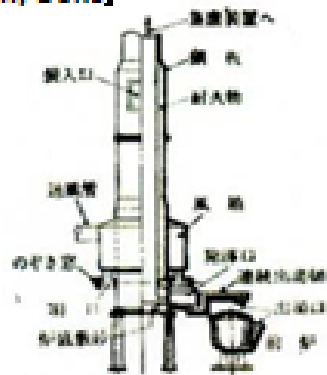
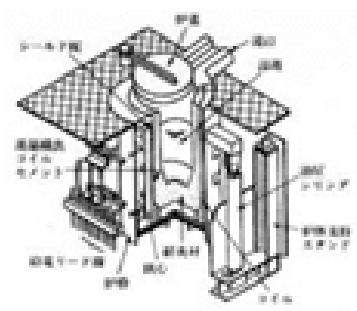

# “Soft” technology for improving energy efficiency of Induction Furnace

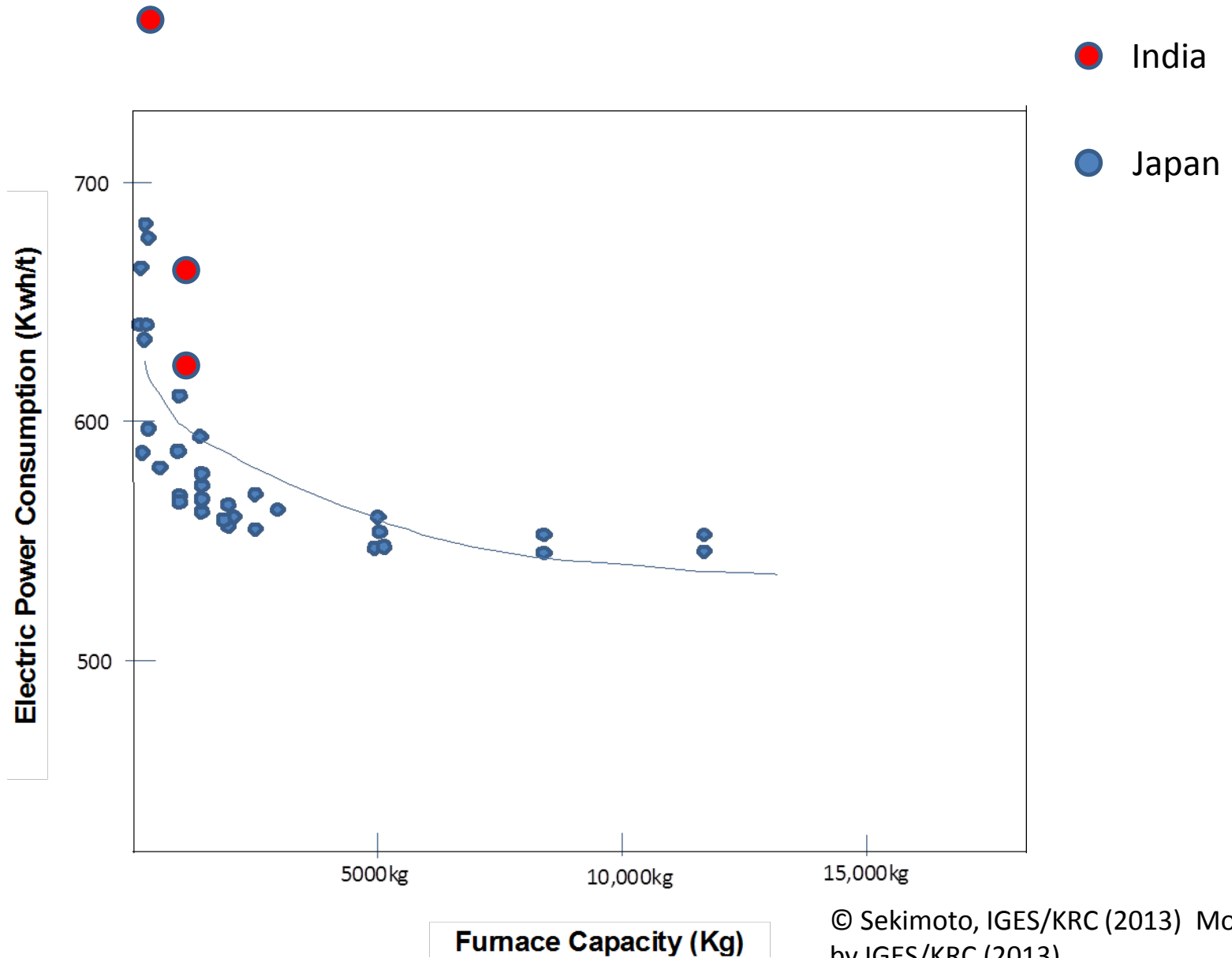

# Example of Soft technology

## Kaizen Activities for improving efficiency of Induction Furnace

Efficiency of 5S activity	Improving work efficiency	Reduction of waste of time searching for things Reduction of wasted work by thoroughgoing direction Reduction of unnecessary transportation by control of unfinished products
	Improving of quality	Reduction of defects from mistake of materials Reduction of defects by control of diagrams and specifications Reduction of number of handling complaints
	Ensuring safety	Safety by ensuring walkways and passages Safety by thoroughness of sign and indications Safety work by thoroughgoing discipline
	Getting delivery date	Clarification of direction by organizing information Improvement in control by thoroughgoing management of stock on hand Thoroughness of demand by process control
	Improving work climate	Thoroughness of time management by discipline Thoroughness of the dress by discipline Thoroughness of the greeting by discipline
	Improving customer's trust	Improvement in reliability to quality of customer through 5S activity

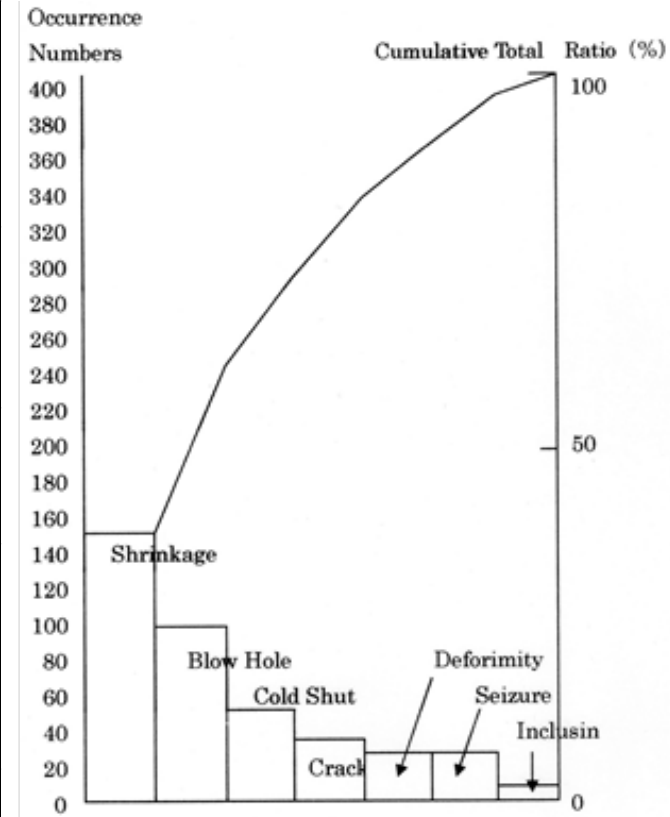

Pareto Chart for defects of casting

# Findings from ALCT Project

- SMEs play a key role in economic growth in India and other developing countries.
- Large number of SMEs belong to energy-intensive high GHG emitting industries (i.e., foundry, dairy, etc.)
- For these SMEs, special attention should be paid from the context of energy, environment and social policies, or sustainable development
- For these SMEs, a number of technological options exist for improving energy efficiency, reducing carbon emission and reducing energy cost.
- For these SMEs, there is a big potential to develop a programme-based / sector-based MRV.
- However, there is very limited available data for these SMEs (i.e., number and types of units (plants), energy consumption, GHG emissions, number of employees, etc.), which prevents us to take appropriate actions for mitigating climate change from the context of sustainable development.
- The above problem occurs due to Lack of finance, capacity and information.
- Therefore, technological cooperation for SMEs is essential to enhance national mitigation actions in developing countries.

# Asia-Pacific Network for Global Change Research (APN)

An inter-governmental network of 22 countries in the Asia-Pacific to foster global change research in the region

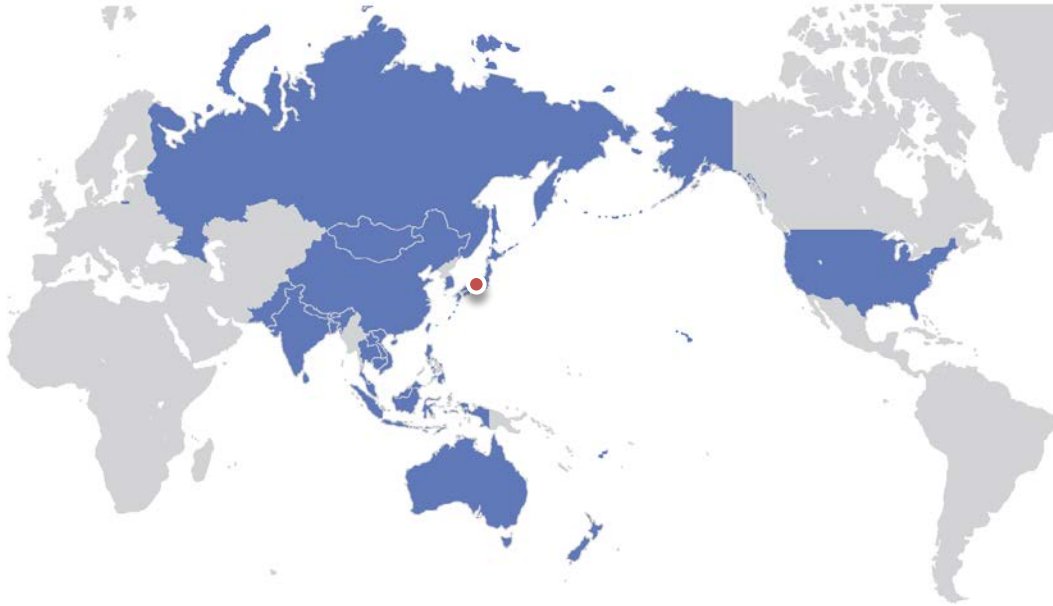

- Established **1996**
- Secretariat in **Kobe**, Japan since 1999
- Financial contribution from four donor countries: **Japan, USA, Republic of Korea, New Zealand**
- Financial Resources: **US\$ 3.4 Million** (2013/14)
- Core programmes
  - ARCP :funding **regional research activities**
  - CAPaBLE: funding **capacity building activities**
- Focused activities: **low carbon, adaptation, ecosystem & biodiversity**

*\* Pacific Island Countries, Singapore , Myanmar and Maldives are approved countries whose scientists are eligible to receive funding under APN awards.*



Low Carbon Initiative Research Base Funded Projects	
Dr. Lakshmi, Development Alternatives, India	Identification of policy and institutional gaps, drivers and strategies to scale-up low carbon and energy efficient technology application in the construction and infrastructure sectors in South Asia
Dr. Dhakal, AIT, Thailand	Understanding and Quantifying the Water-Energy-Carbon Nexus for Low Carbon Development in Asian Cities
Assi. Prof. Lopez, Universty of The Philippines Visayas	Assessment of Carbon Sequestration through Vermitechnology in Organic Farming
Prof. Damasa Macandog, University of Philippines	Integrated sustainability assessment of bio energy potentials in Asia: An application of a hybrid approach on trade-offs and pathway
Dr. Jupesta UNU-IAS & Ms. Wakiyama IGES	Low Carbon Urban Infrastructure Investment: Cases of China, Indonesia, and Japan

Low Carbon Initiative: Capacity building funded projects	
Mr. Maeda, IGES Kitakyushu	Capacity Building for Implementing a ‘Measurable, Verifiable and Reportable (MRV)’ Model in a Mid-Sized Thai Municipality
- Ms. Guerrero, Non Timber Forest Products -	Strengthening Community Voices in REDD+ Policy

# APN's 2013 Calls for Proposals under APCP for Regional Research CAPaBLE for Scientific Capacity Development

The APN is inviting proposals under two separate programmes, the [ARCP Programme](#) and the [CAPaBLE Programme](#), for funding **in 2014 (from June for CAPaBLE and from October for ARCP)**, and is able to provide a limited amount of financial support for research and capacity development activities that fall within its areas of interest.

Stage 1. Submission of **Summary Proposal** : **Sunday 11 August 2013**

Stage 2. Submission of **Full Proposal** by the Successful Stage 1 Proponents

For further information, please visit the APN Website

<http://www.apn-gcr.org/2013/06/14/2013-calls-for-proposals-under-the-arcp-and-capable-programmes/>

